



MACCHINE SPECIALI SRL

Via Remo Brambilla n. 2
20863 Concorezzo (MB)
Milano - Italy
Tel. ++ 39 039 6040490
Fax ++ 39 039 6049961
E-mail: macchinespeciali@macchinespeciali.it
Internet: <http://www.macchinespeciali.it>

rif. 3.0500.2



LONGITUDINAL TAPING DEVICE "NLD500/330"

PRODUCTS

L.A.N. cables
produced with double
or single twist
machine lapping with:
Aluminium,
Polyestere,
Polypropylene and
Polyethylene tapes.

Tape tickness
range:
12 - 40 micron

Tape width range:
from 12 - 40 mm.



DIMENSIONS

SPOOLS OR PADS
- max. dia. 500 mm.
- max. width 330 mm.
- Hole 3" (76)

Several pads can be
used at the same time

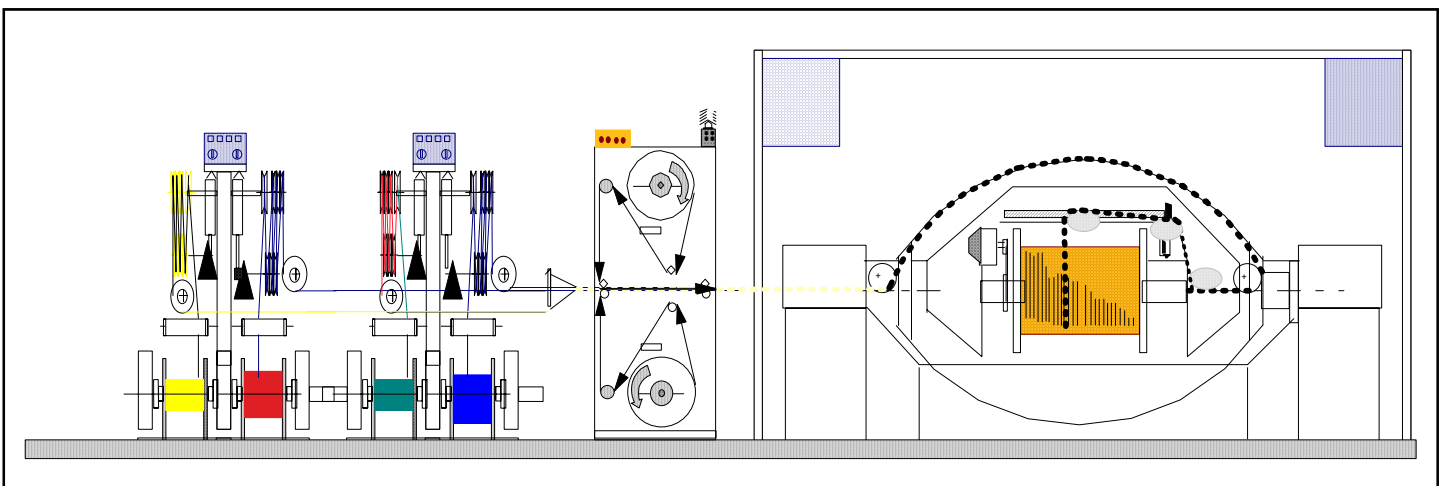

MAIN FEATURES

- Auto setting of the tension by the load cell and PLC.
- Alarms of minimum tension and minimum tension.
- Allarms of pre-end of the pad
- Display that show the real tension on the product just in time